

1 2 3 4 5 6 7 8

A

PANO TİPİ : PMK SERİSİ FREKANS KONTROLLU PANO
PANEL TYPE : PMK SERIES FREQUENCY CONTROL PANEL

A

B

TEKNİK BİLGİ (TECHNICAL INFO)

B

POMPA SAYISI (PUMP NUMBER) : 3
POMPA GÜCÜ (PUMP POWER) :kW
POMPA AKIM (PUMP CURRENT) :A
VERSİYON (VERSION) : K.2.5.16-1
BAĞLANTI TİPİ (CONNECTION TYPE) : **YILDIZ ÜÇGEN BAĞLANTI (STAR DELTA CONNECTION)**
BESLEME GERİLİMİ (SUPPLY VOLTAGE) : 3X400 V / 230 V 50-60 Hz. AC , PE
ÇALIŞMA SICAKLIĞI (RUN HEAT) : -20 / +50c
KORUMA SINIFI (PROTECTION CLASS) : IP 55

C

C

D

D

PANO KODU (PANEL CODE) :
PMK03/YU70 PMK03/YU75
PMK03/YU11 PMK03/YU90
PMK03/YU15 PMK03/YU110
PMK03/YU18 PMK03/YU132
PMK03/YU22
PMK03/YU30
PMK03/YU37
PMK03/YU45
PMK03/YU55

E

E

F

F

1 2 3 4 5 6 7 8

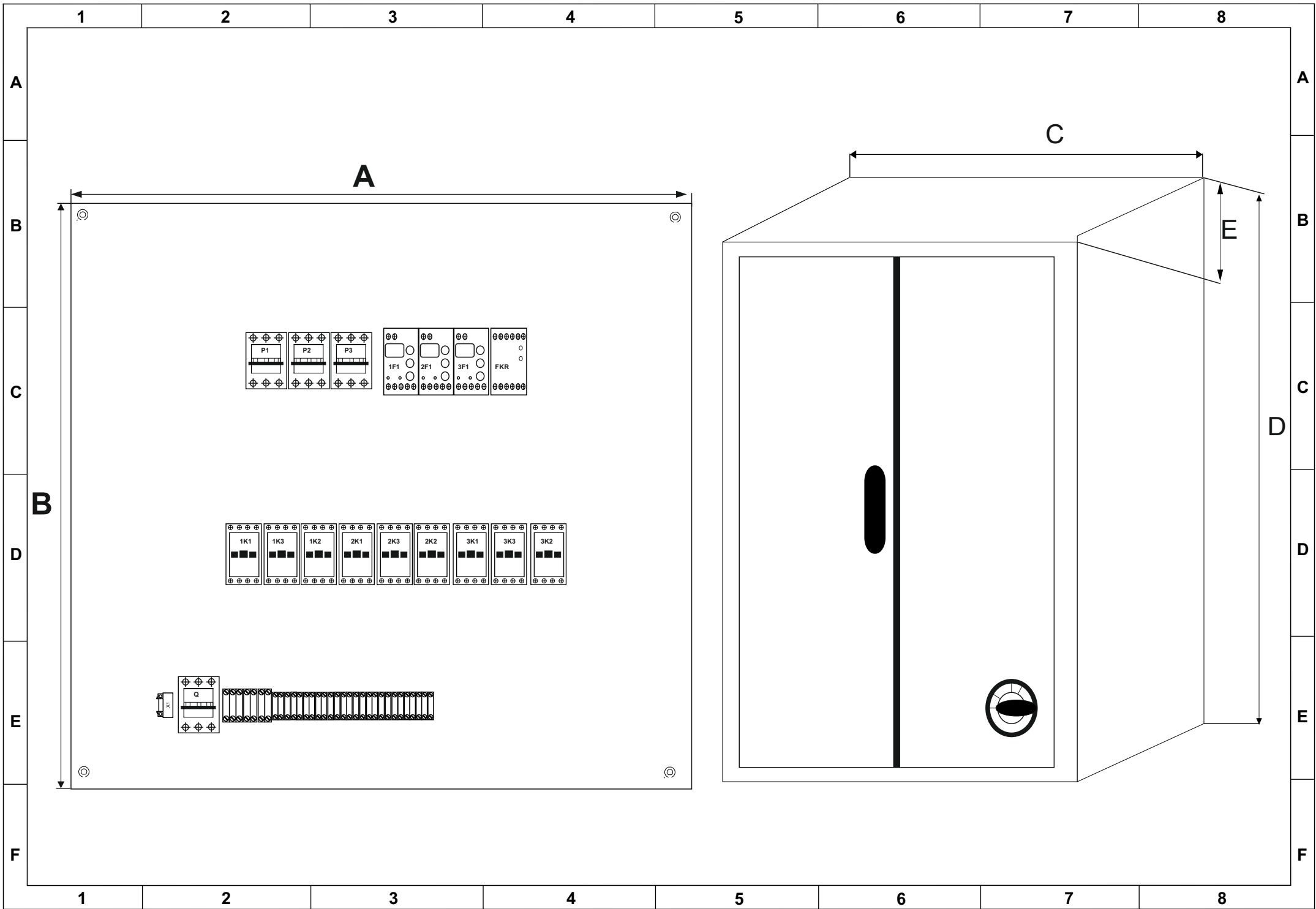

1

2

3

4

5

6

7

8

A

PANO ÖLÇÜLERİ
(PANEL DIMENSIONS)

GÜÇ POWER	A	B	C	D	E
7,5kW	440mm	640mm	500mm	700mm	260mm
11kW	440mm	640mm	500mm	700mm	260mm
15kW	440mm	640mm	500mm	700mm	260mm
18kW	440mm	640mm	500mm	700mm	260mm
22kW	440mm	640mm	500mm	700mm	260mm
30kW	640mm	940mm	700mm	1000mm	320mm
37kW	640mm	940mm	700mm	1000mm	320mm
45kW	640mm	940mm	700mm	1000mm	320mm
55kW	640mm	940mm	700mm	1000mm	320mm
75kW	900mm	1200mm	1000mm	1300mm	380mm
90kW	900mm	1200mm	1000mm	1300mm	380mm

B

C

D

E

F

1

2

3

4

5

6

7

8

A

B

C

D

E

F

MALZEME TABLOSU
MATERIAL TABLE

CODE POWER	Q	1K1	1K2	1K3	2K1	2K2	2K3	3K1	3K2	3K3	P1	P2	P3
7,5kW	63A	9A	9A	9A	9A	9A	9A	9A	9A	9A	32A	32A	32A
11kW	125A	12A	12A	12A	12A	12A	12A	12A	12A	12A	40A	40A	40A
15kW	125A	18A	12A	18A	18A	12A	18A	18A	12A	18A	63A	63A	63A
18kW	125A	25A	12A	25A	25A	12A	25A	25A	12A	25A	63A	63A	63A
22kW	160A	25A	18A	25A	25A	18A	25A	25A	18A	25A	63A	63A	63A
30kW	200A	40A	25A	40A	40A	25A	40A	40A	25A	40A	100A	100A	100A
37kW	200A	40A	25A	40A	40A	25A	40A	40A	25A	40A	125A	125A	125A
45kW	250A	50A	32A	50A	50A	32A	50A	50A	32A	50A	160A	160A	160A
55kW	400A	65A	40A	65A	65A	40A	65A	65A	40A	65A	160A	160A	160A
75kW	400A	80A	50A	80A	80A	50A	80A	80A	50A	80A	250A	250A	250A
90kW	630A	115A	80A	115A	115A	80A	115A	115A	80A	115A	250A	250A	250A
110kW	630A	115A	80A	115A	115A	80A	115A	115A	80A	115A	250A	250A	250A
132kW	800A	160A	115A	160A	160A	115A	160A	160A	115A	160A	400A	400A	400A

3/N,PE,50Hz. 380/220V AC.

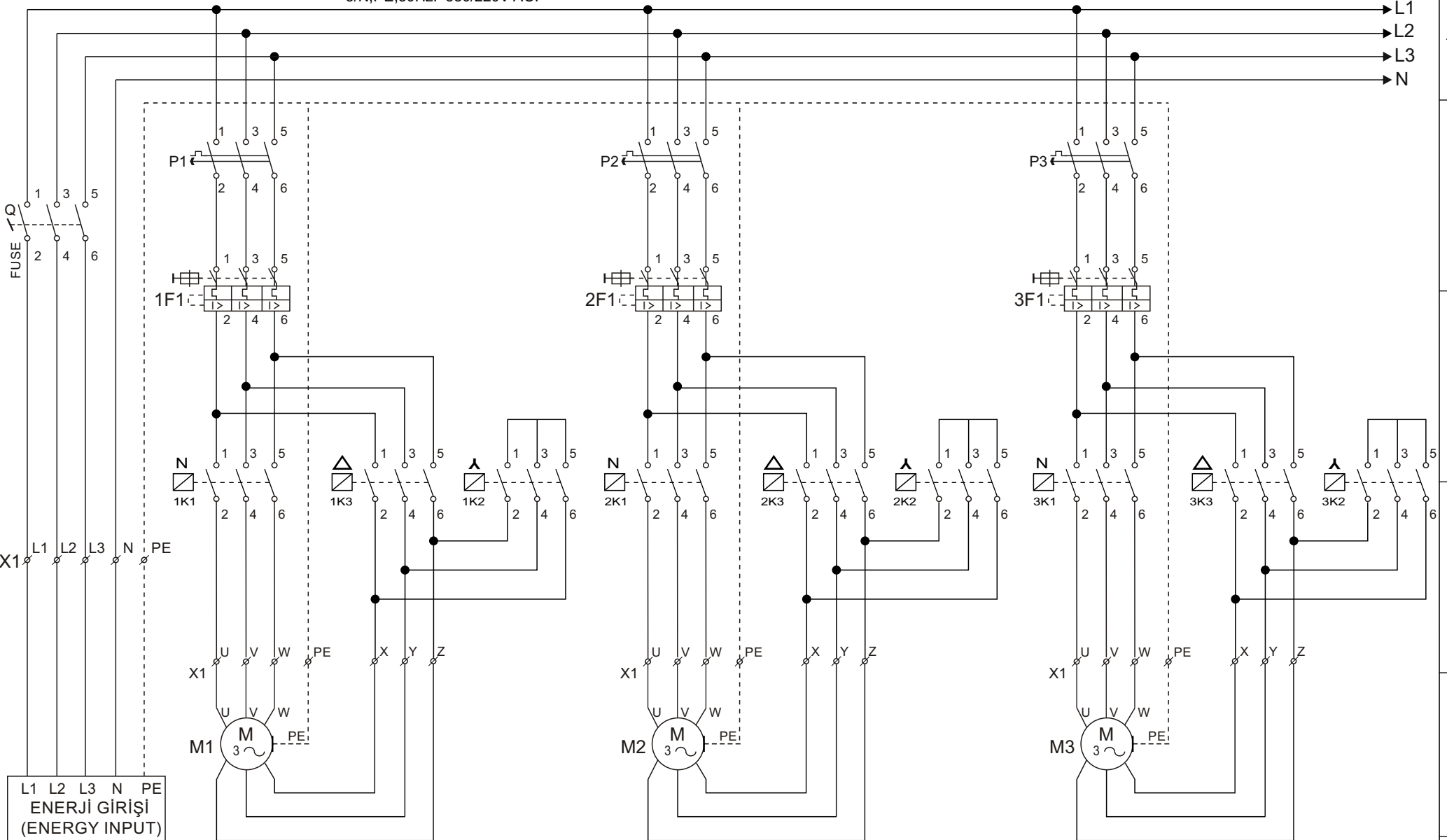

**PANOYA MUTLAKA
TOPRAKLAMA YAPINIZ
(MUST BE GROUNDED TO
THE PANEL)**

**POMPA-1
(PUMP-1)**

**POMPA-2
(PUMP-2)**

**POMPA-3
(PUMP-3)**

SAYFA
1 / 3

3 POMPA YILDIZ ÜÇGEN KONTROL PANOSU

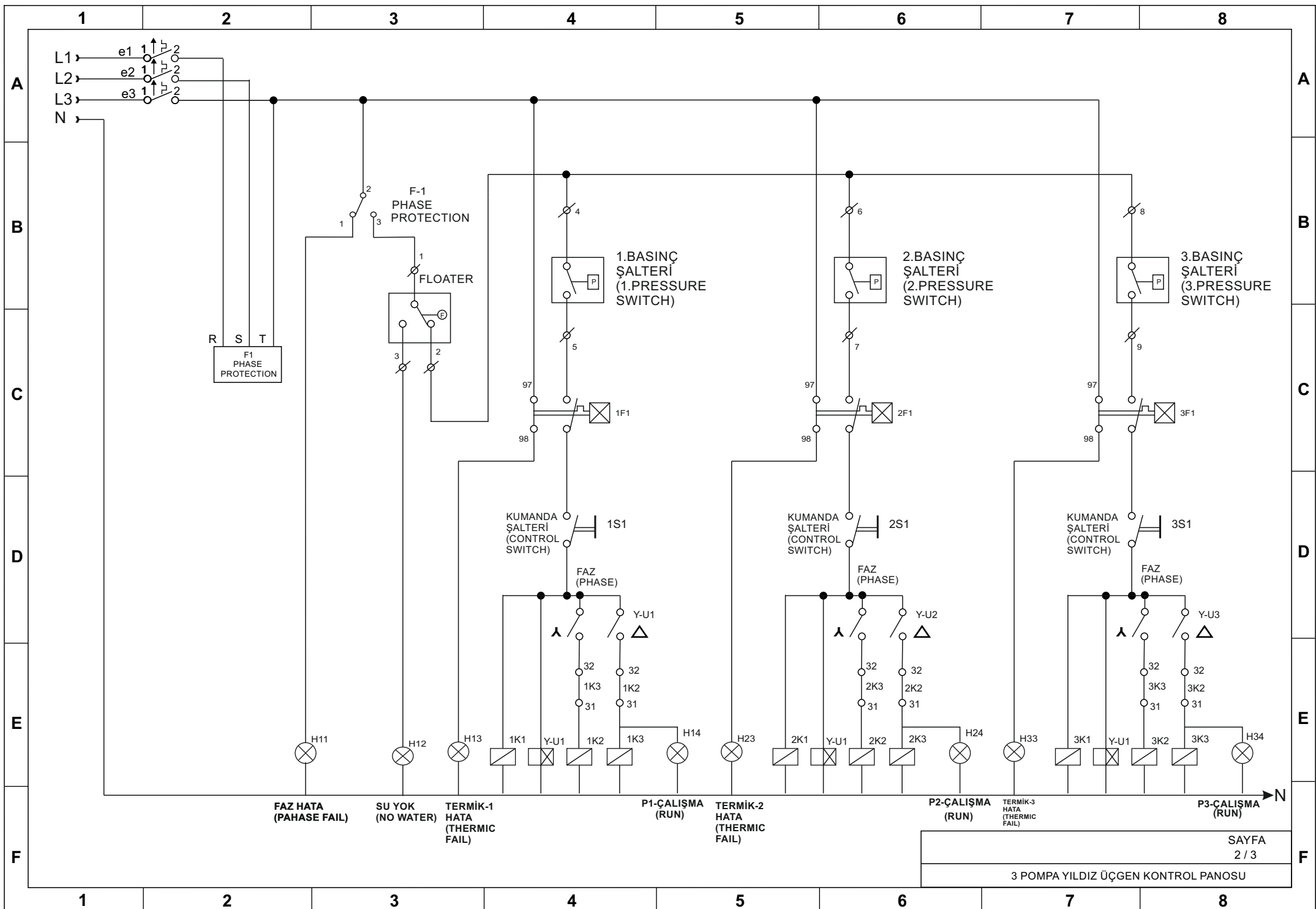

CONNECT DIAGRAM

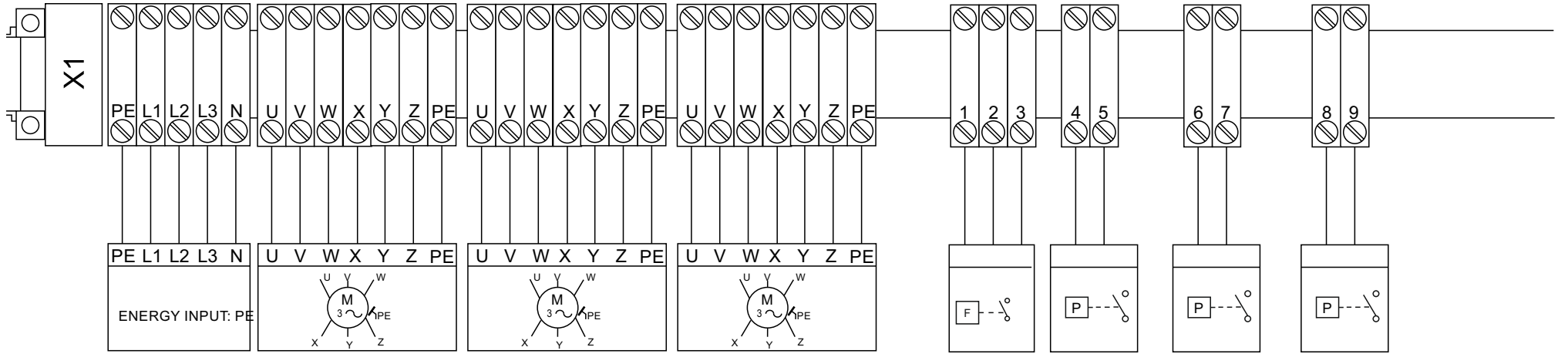

ENERGY INPUT: PE

ENERGY INPUT

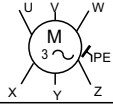

M1

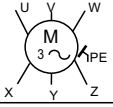

M2

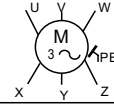

M3

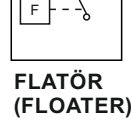

FLATÖR
(FLOATER)



1. BASINÇ
ŞALTERİ
(1. PRESSURE
SWITCH)



2. BASINÇ
ŞALTERİ
(2. PRESSURE
SWITCH)

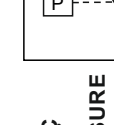

3. BASINÇ
ŞALTERİ
(3. PRESSURE
SWITCH)